



FITTING AND OPERATING GUIDE



12v/24v Wireless Remote, Receiver and Solenoid

VERY IMPORTANT - YOU MUST READ AND UNDERSTAND THIS GUIDE
BEFORE INSTALLING AND OPERATING YOUR WINCH

Thank you for buying a genuine WINCHMAX wireless remote control kit. This should provide many years of trouble free operation, however it is essential that it is correctly installed otherwise irreparable damage to the micro circuitry/contacts will be caused.

This product is available in single and double handset versions and several types of control box/receiver. This manual is common to all 'Keyhole' style transmitter controls.

IMPORTANT

PLEASE READ AND UNDERSTAND THIS ENTIRE MANUAL BEFORE INSTALLING OR OPERATING THIS PRODUCT – FAILURE TO DO SO COULD RESULT IN DAMAGE TO PROPERTY, SERIOUS INJURY OR DEATH. UNDERTAKE A FULL SAFETY CHECK AND RISK ASSESSMENT BEFORE EACH USE.

GETTING STARTED

- Warning: to prevent damage or injury in the case of unintended operation always electrically isolate any equipment when not in use.
- Please note that this remote control unit (receiver and remote control) has been fully tested before being despatched and is in full working order.
- As the most common cause of damage is incorrect wiring we ask our customers to test the unit themselves before installation and report any problem at that time
- If you have any doubt as to the correct wiring please do not attempt connection before checking with us. Our telephone contact is 01986 899264
- Accidentally allowing an output to connect to earth/ground, or by 'flashing' an output onto a connection will destroy the receiver. If the unit is damaged as a result of incorrect installation we cannot be held responsible for the damaged caused.
- Keyhole Style Remotes:
 - The winch is supplied with two types of remote control; a plug-in wander lead and
 - wireless remote control. The plug-in wander lead is considered to be the primary control
 - system and allows very precise control. It should always be kept available for use.



On/Off Indicator Light

Winch In/Out Controls

Press both buttons together for 3 seconds to power on/off

- The plug-in wander lead will either have a direct push-fit three-pin plug (17,000lb/20,000lb) or a push and twist 'bayonet fitting' (13,500lb). With the bayonet fitting, the plug should be lined up with the keyway (approximately 11 o'clock) on the socket and fully inserted, then rotated clockwise until the silver clip is directly at the top (12 o'clock).
- The wireless remote control receiver is pre-installed into the control box. To power on the transmitter hold down both the IN and OUT buttons for approximately 3 seconds until the power light illuminates.
- The remote control is now active hold either the IN or OUT button to operate.
- Repeat the above procedure to turn off manually.
- If the transmitters are left on and unused for approximately 5 minutes they will auto power-off to preserve the battery.
- If the power light fails to illuminate or becomes weak, please replace the batteries. Each transmitter contains 2 no. CR2032 (3V) button cells
- Always keep the wireless transmitters safe and dry and protect from unauthorized/accidental operation.

WIRING YOUR SOLENOID

Warning: to prevent damage or injury in the case of unintended operation always electrically isolate any equipment when not in use.

Note: trigger wire colours may vary.

- Terminal 2 is the earth supply to the solenoid.
- Energise terminal 1 = 5 connects to 6 & 4 connects to 7
- Energise terminal 3 = 5 connects to 7 & 4 connects to 6
- No input (at rest) = 6, 7 & 4 connected. 5 open circuit (no connection)

The basic principle of operation is that once connected to a power supply, the two output wires of the receiver will go to the supply voltage (12v or 24v depending on the model) when the corresponding button on the transmitter (hand set) is pressed.

The output can then be used to operate the trigger terminals on a secondary contactor (solenoid) to switch the main load (e.g. a Winch). The outputs **MUST NEVER** be connected to earth as otherwise they will short circuit and burn out.

If you have any doubt about which are the trigger terminals on your solenoid, first check by using a thin piece of wire connected to the positive supply, when you apply it to one of the solenoid trigger terminals the winch should run in one direction, if you apply it to the trigger terminal it should operate in the opposite direction.

In most cases winches are fitted with a plug in wander lead, at the back of the wander lead socket you will see three wires. One of the wires is the positive feed to the wander lead switch, depending on which way the switch is pressed this feed will then be diverted down one of the other two wires (the output wires) which will in turn be connected to the trigger terminal of the solenoid.

There are many different types of control configurations, but if you understand the basic principle of operation this should allow you to apply it to whichever set you have. We have provided a schematic of the most common single solenoid park winch control system (in our diagram trigger terminals on the solenoid are labelled as '1' & '3') but if you have any doubt as to how you should connect your remote our office hours helpline for advice on 01986899264 or email info@winchmax.co.uk

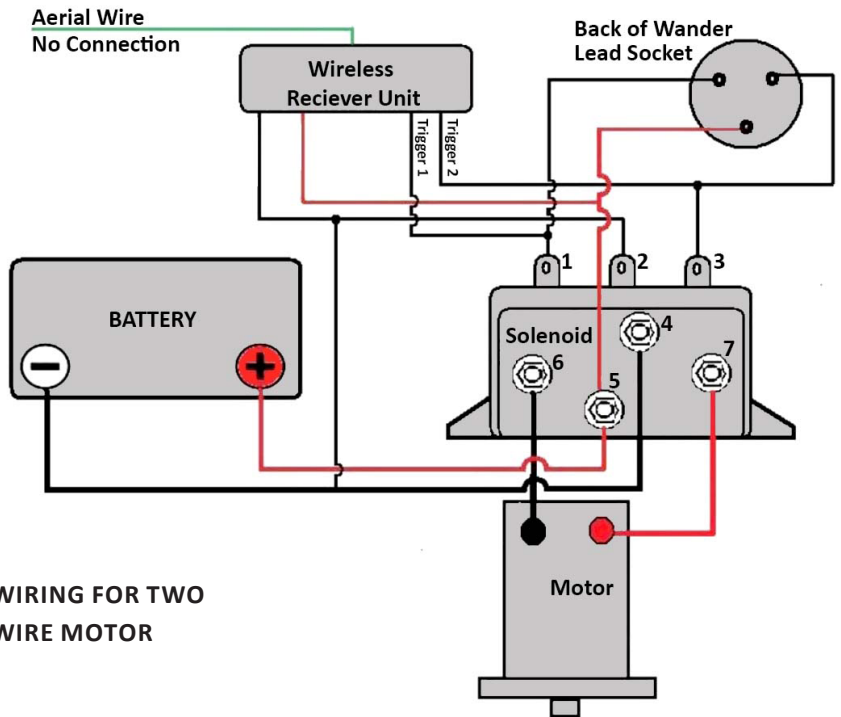

WIRING FOR TWO
WIRE MOTOR

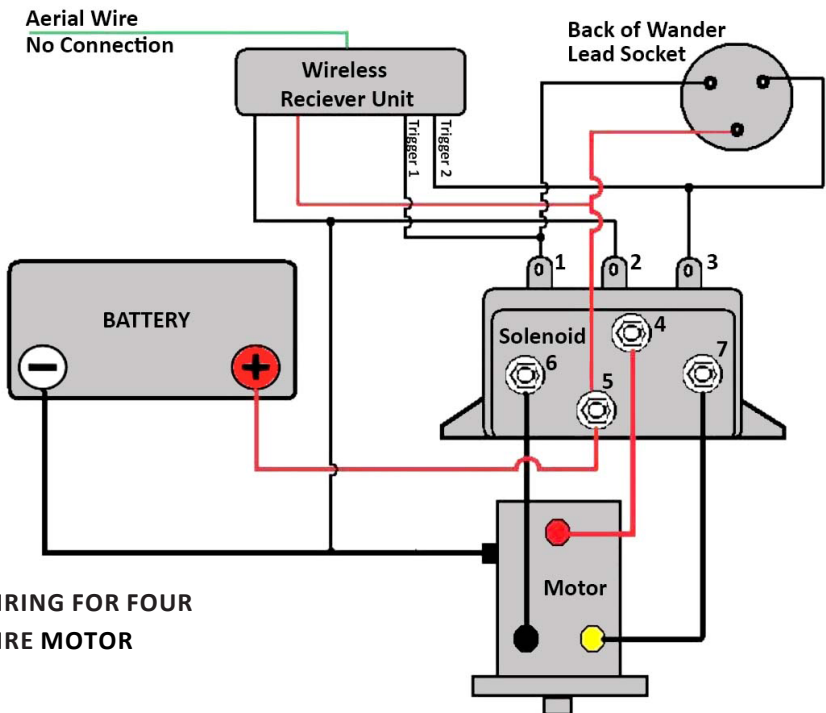

WIRING FOR FOUR
WIRE MOTOR



WINCHMAX LTD

The Powerhouse,
Earsham Hall,
Bungay,
Suffolk,
NR3452AN.

info@winchmax.co.uk

Tel +44(0)1986899266

Registered in England No. 4083040

WARRANTY

This product is covered by a limited RTB (return to base) warranty for a period of 12months. In the case of product failure, please return to Winchmax UK ensuring that you enclose proof of purchase and full contact details. Once the item has been inspected we will contact you to report our findings and if failure is dues to manufacturing defect we will repair or replace the item at our discretion. Winchmax UK cannot be held responsible for any consequential loss or damage due to the failure of this device.

WINCHMAX LTD
WWW.WINCHMAX.CO.UK